

The KS108 is a single-quota positioner. The selection of the quota to be reached is made through the keypad setting (KEY F). When the start is pressed, the instrument automatically performs the quota by acting on the 4 relay outputs. By moving the axis in manual mode the instrument works as a meter and displays the encoder supplied value.

Using the Start and Stop commands the instrument works as an automatic positioner enabling the axis movement in relation to the set quota value and choosing the movement direction itself, it compares the position in which it is located with the quota to be reached and enables the relative relay outputs following the set general parameters.

Technical features

| | |
|----------------------|---|
| Power supply | 24Vac / 24Vdc +/- 5% |
| Absorption | Max 4VA nominal |
| Display | 6 red 7-segments displays H13mm |
| Keyboard | 4 Mechanical keys |
| Microprocessor | 16 Bit + Flash-Eprom |
| Memory | Eeprom 256Kbit |
| Operation conditions | 0.. +55°C / 20..90% R.U. without condensation |
| Storage conditions | -25.. +80°C / 20..90% R.U. without condensation |
| Mounting | recessed mounting |
| Container | Black ABS |
| Protection degree | IP20 |

Electrical connections

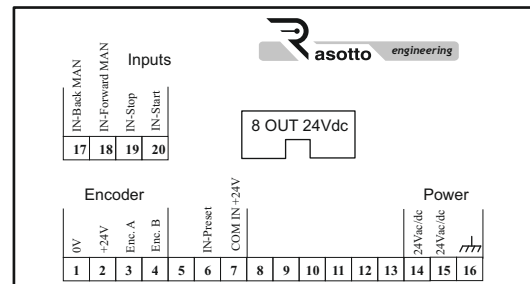

Dimensions

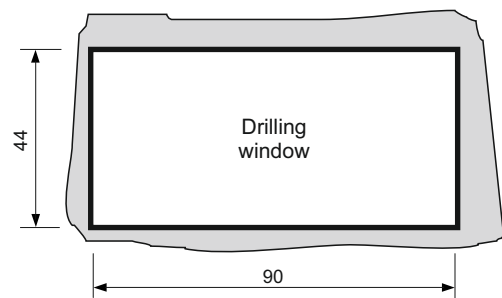
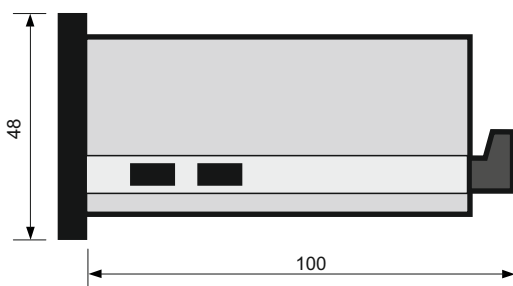

The displaying

The display is made up of 6 7-segment displays, height 13mm.

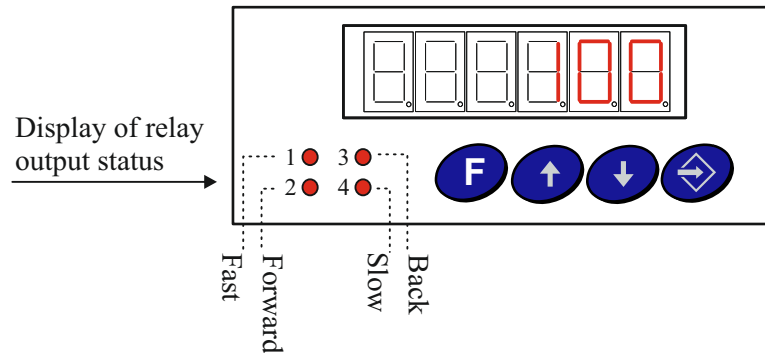

The keyboard



Key for entering the quota to be reached

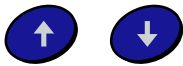

Functions scroll keys



Press to enter programming and confirm the set data

The leds

- 1 ● On if fast motion relay is active
- 2 ● On if forward motion relay is active
- 3 ● On if back motion relay is active
- 4 ● On if slow motion relay is active

Warnings

1. The KS108 instrument is a control product and not a production product.
2. The DSSTech s.r.l. company declines all responsibility for damage to things and people if the instrument is not used according to the technical guidelines provided by the manufacturer.
3. The company DSSTech s.r.l. declines all responsibility for open or tampered products.
4. Electrical diagrams and technical manuals are the exclusive property of the DSSTech s.r.l. company and any unauthorized reproduction will be prosecuted according to the law.

Operation cycle

After programming the instrument according to the instructions below, a complete work cycle can be performed. Press the F KEY and enter the desired quota, confirm the value entered with the ENTER KEY.

At this point the operator has 2 commands:

with the start impulse (START INPUT) if the quota to be reached is higher than the current position value, the instrument will enable the fast and forward outputs, proceeds with the slow speed insertion by comparing the set slowdown value and will disable the outputs blocking the movement on the set quota value. If, on the other hand, the quota to be reached is lower than the current position value, the instrument will enable the back and fast outputs, exceed the quota to be reached for the set play recovery value, activate the forward and slow outputs and disable the outputs blocking the movement on the set quota value. This standard operation depends on the set slowdown values, the play recovery value and the +/- sign set for each value.

At any time you can intervene during the axis movement by pressing the stop button.

Subsequently, it will be possible to start again from the locked position with another start command or it will be possible to modify the quotas and the parameters that are deemed opportune.

At each reached quota, the position relay will be enabled, if the MR80 board is available, while with the MR40 board this function is not available.

After pressing the stop button (relative input), the machine manual movement will be possible through the two specific inputs and the instrument will in this phase operate like a position viewer.

The Encoder

The encoder is connected to the terminal board on the back of the instrument with terminals N.1 - 2 - 3 - 4.

The encoder must be incremental type chosen with the number of pulses per revolution suitable for the system required precision. The encoder must work with 24Vdc power supply and the two A - B channels must be PUSH - PULL type. Pay attention to the encoder connection so as not to damage it. **The encoder cable must be of a shielded type with ground shielding only on the instrument side;** it must be kept away from electromagnetic interference sources such as motors, inverters, contactors, etc. and it is advisable to use separate raceways.

The interface

The instrument must be interfaced with an MR40 (4 relay) or MR80 (8 relay) module through the connector on the back. It is necessary to use a 10-pole flat cable which must be positioned away from electromagnetic interference sources such as motors, inverters, contactors, etc. It is advisable to use separate raceways and, if necessary, use shielded cable with ground shielding only on the instrument side.

MR40 or MR80 modules with relay outputs

MR40 and MR80 are relay modules for interfacing the instrument to the motor or to the axis displacement inverter.

The commands arrive at the instrument outputs and each command is displayed with signaling LED.

The connection to the instrument is made with a 10-pole flat cable by connecting it to the connector on the instrument back. The 10-pole flat cable must be kept away from electromagnetic interference sources such as motors, inverters, contactors, etc. It is advisable to use separate raceways and, if necessary, a shielded cable with ground shielding only on the instrument side.

You can connect loads up to 250Vac / 10A AC1 to each individual relay contacts.

OPERATING MENU

After programming the TECHNICAL PARAMETERS MENU, the instrument is ready to start operation. To select the quotas to be reached after pressing the START button, follow the procedure below. Remember that the quotas settings will be possible only if the instrument is in STOP mode; if the instrument is executing a quota, the operation menu is disabled.

When switched on, the instrument displays:

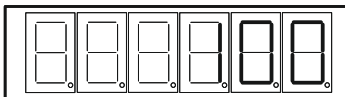

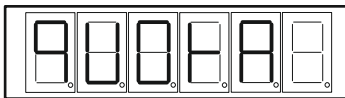

Current position where the machine is (for example 100)

Press  to enter the OPERATION MENU and the display will show



the word QUOTA, confirm with the key  and

using the arrow keys   set the desired quota

confirm the set value with the key  and the display will return to the initial screen

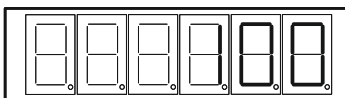

and will display the real machine measurement (100 in this example)

At this point the instrument is ready for processing and is waiting for the START key to be pressed. When the start is pressed, the display will show the moving quota and activates the relative outputs also shown on the front panel with the 1-2-3-4 LEDs. Once the quota is reached, the position will stop and the outputs will all be off.

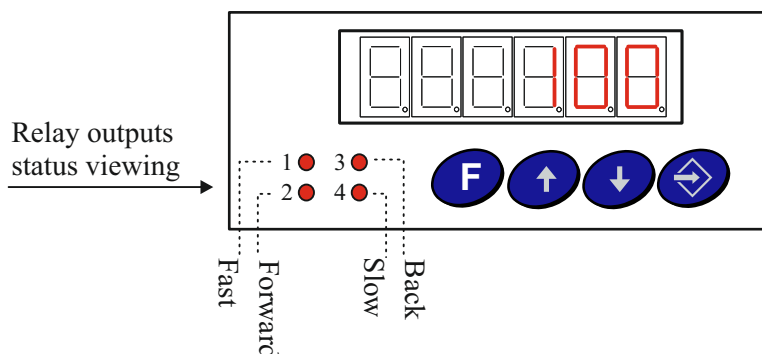

TECHNICAL PARAMETERS SETTING MENU

The technical parameters are protected with password to prevent inadvertent changes that would result in malfunction. The technical parameters are divided into 4 different menus that can be configured by pressing the ENTER key and inserting the respective password:

1- MAIN MENU (PASSWORD 569)

This menu contains the main operating parameters:

1. DP - Decimal point, comma setting.
2. Coefficient - Encoder impulse correction coefficient and position to be displayed.
3. Tolerance - Tolerance value accepted on the quotas to be reached.
4. Inertia - Machine mechanical inertia value.
5. Play rec. - Mechanical play recovery in forward or backward movement.
6. Slowd. quota - Position value at which the instrument will switch from fast to slow speed.
7. Exit time - R5 output activation time in 1/10 of a second at the reached quota (only with MR80).
8. Current quota - Set new position value. (In case you want to correct the position).
9. Preset quota - Position setting to be loaded when the start is pressed (optional AUTOPRESET function).
and self positioning quota by pressing the preset input (optional PRESETQUOTA function).

2- VIRTUAL ELECTRONIC LIMIT SWITCHES MENU (PASSWORD 570)

The electronic or virtual limit switches allow the machine to be protected against the insertion of not permissible quotas by the machine and which could damage the machine itself.

In order to avoid the insertion of incorrect quota values, it is possible to enable and insert upper and lower margins, beyond which the instrument does not allow insertion and also blocks movement.

Obviously, such electronic or virtual limit switches do not have the same guarantees as physical limit switches positioned on the machine itself and therefore it is advisable to use both solutions.

3- ENCODER COEFFICIENT AUTOMATIC CALCULATION MENU (PASSWORD 571)

This menu allows the encoder coefficient automatic calculation to adapt the displayed position according to the pulses number of the installed encoder.

4- INERTIA AUTOMATIC CALCULATION MENU (PASSWORD 572)

This menu allows the inertia automatic calculation linked to the machine's mechanics on which the positioner is installed.

1- MAIN MENU (PASSWORD 569)

To enter the MAIN MENU area, follow the procedure described here, but remember that to enter the menu the machine must be in STOP phase.

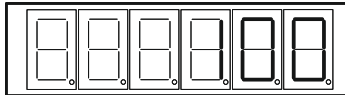

When switched on, the instrument displays:



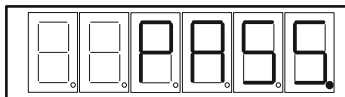

The display shows the current position where the machine is (in this example 100)

Press the button  and the message PASS will appear on the display.

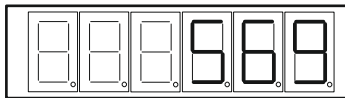

Press  and using the arrow keys   enter the password 569:



Confirm with the key  and enter the main menu and the first displayed item is decimal point DP:

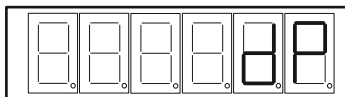

Press  and using the arrow keys   place the comma at the desired point:

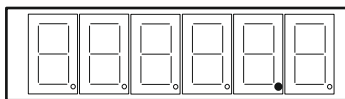

In this example the comma is set in the second display because you want to display only a decimal place.

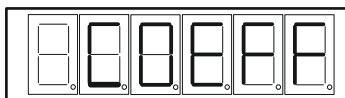

Confirm the desired position with the key  and the display will show the second parameter COEFFICIENT:

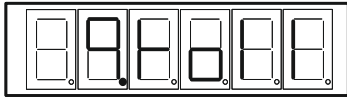

Press  and use the arrow keys   to set the desired value, or use the automatic calculation explained in the COEFFICIENT AUTOMATIC CALCULATION MENU

Confirm with the key  and the third parameter TOLERANCE QUOTA will be shown on the display:





Press  and using the keys   set the tolerance value on the quota you want to obtain, the set value represents the tolerance that is considered acceptable with respect to the quota to be reached, for example a tolerance of 0.5 identifies that on a set quota of 100.0 any value between 99.5 and 100.5 is considered acceptable.

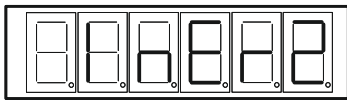

Confirm the desired value by pressing the key  and the display will show the fourth INERTIA parameter:

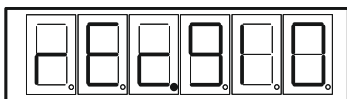

Inertia is the machine movement from the moment the instrument disables the outputs to block the movement itself. The instrument has a inertia value self-learning function that allows the setting in a quick and simple way: if you want to use it, follow the INERTIA AUTOMATIC CALCULATION MENU procedure.

Otherwise you can use the keys   and then confirm with  to go to the fifth parameter PLAY REC.:



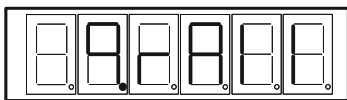

The play recovery setting allows the positioner to always reach the quota from the same movement direction, so as to reduce measurement errors due to mechanical plays that are inevitably present on any machine. If you want to reach the quota always moving forward you have to set a positive plays recovery, otherwise set a negative plays recovery value. Use the keys   and confirm with  to go to the sixth parameter SLOW DOWN QUOTA:



ATTENTION:



The value of the slowdown quota must be at least twice the value of the Inertia.

The slowdown quota is the deviation value respect to the quota to be reached in which the instrument will switch from fast to slow speed. The slowdown is carried out in the forward direction if the play recovery is positive, otherwise in the reverse direction if the play recovery is negative. The slowdown quota is important to reach the quota always at the lowest speed so as to ensure greater accuracy.

Use the keys   to modify and confirm with  to switch to the seventh parameter

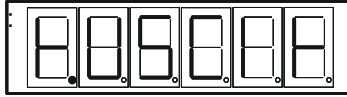
OUTPUT TIME displaying:



Using the keys   you set the time in tenths of a second where the output (quota in position) remains enabled, present output only if the MR80 interface is available.

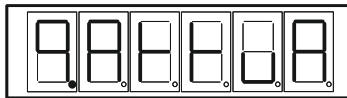

The output (quota in position) is activated when a quota is reached to signal this event; if the time is set to zero (0) the output remains enabled continuously until the next positioning, otherwise will follow the set time.

Set the desired value and confirm with the key  to switch to the eighth parameter ACTUAL QUOTA :



The displayed value represents the position where the machine should be; check if this position is correct and if necessary change the value to align it with the actual measured quota.



This parameter also serves to realign the instrument with the real machine position in case, for any reason, the real position does not respect the instrument displayed value.

Use the keys   to change the value and / or confirm with  to move to the ninth parameter

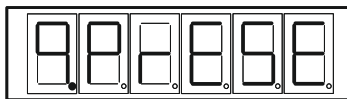
QUOTA PRESET (OPTIONAL FUNCTION):



Quota preset is the value that will be loaded as current position when the start is pressed if the optional AUTO PRESET function is enabled. Or it is the quota that will be automatically reached when the PRESET input is pressed if the optional PRESET QUOTA function is enabled.

Use the keys   to change the value and confirm with  to exit programming.

2- VIRTUAL ELECTRONIC LIMIT SWITCHES MENU (PASSWORD 570)

The electronic or virtual limit switches allow the machine to be protected against the insertion of not permissible quotas by the machine and which could damage the machine itself.

In order to avoid the insertion of incorrect quota values, it is possible to enable and insert upper and lower margins, beyond which the instrument does not allow insertion and also blocks movement.

Obviously, such electronic or virtual limit switches do not have the same guarantees as physical limit switches positioned on the machine itself and therefore it is advisable to use both solutions.

To insert the electronic limit switches, follow the procedure below:

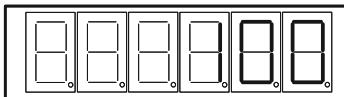

When switched on, the instrument shows:



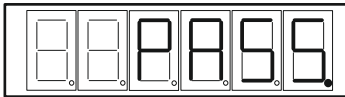

The display shows the current position where the machine is (in this example 100)

Press the button  and the message PASS will appear on the display.



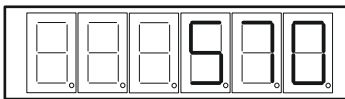



Press  and using the arrow keys   enter the password 570:

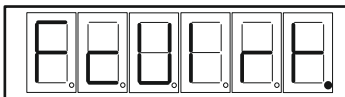

Confirm with the key  and enter the limit switch menu; the first displayed item is VIRTUAL LIMIT SWITCHES:



press the key  and using the keys   set 0 if you do not want the virtual limit switches or 1 if you want the virtual limit switches instead. If the choice is 1 by confirming with the key  the display shows

BACK LIMIT SWITCHES QUOTA:

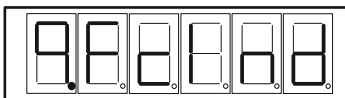

Press the key  and use the keys   to set the lower limit switches value.

Below this set value, the instrument will block the backward movement. If mechanical limit switches are also present, it is recommended to set this limit switch just above the mechanical limit switch position.

Confirm the lower limit switch value by pressing  and you will go to the FORWARD LIMIT SWITCH QUOTA parameter :

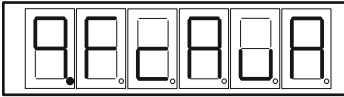

Press the key  and use the keys   to set the upper limit switch value.

Above this set value, the instrument will block forward motion. If mechanical limit switches are also present, it is recommended to set this limit switch just below the mechanical limit switch position.

Confirm the upper limit value by pressing  and you will exit programming by returning to the initial screen.

3- ENCODER COEFFICIENT AUTOMATIC CALCULATION MENU (PASSWORD 571)

The KS108 instrument has a encoder coefficient self-learning function; this mode allows you to configure the encoder pulses / shown position ratio in a simple and fast way without knowing the encoder pulses number and the ratio that binds them to the value that you want to show on the display. It is always possible to manually set the value through the main menu (PASSWORD 569).

To access the ENCODER COEFFICIENT AUTOMATIC CALCULATION menu from the initial screen:

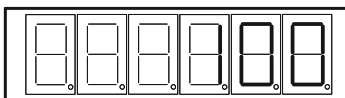

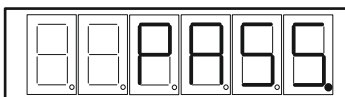

The display shows the current position where the machine is (in this example 100)

Press for the key  and the message PASS will appear on the display:

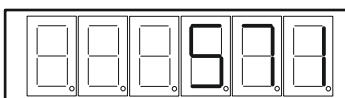

Press  and using the arrow keys   enter the password 571:



Confirm with the key  and enter the automatic coefficient calculation menu and the first item displayed is POSIZ1 (POSITION 1):

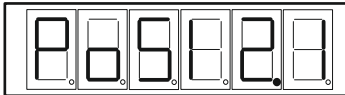

Using the forward-manual and back-manual inputs, position yourself on a known altitude, then confirm with the key  and on the display will be requested before positioning the desired decimal point:

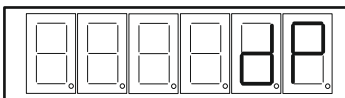



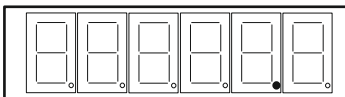

Press  and using the arrow keys   place the comma at the desired point:



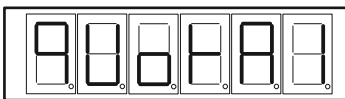

In this example comma is set in the second display because you want to display only a decimal place.

Confirm the desired position with the key  and the display will show the word QUOTA1:



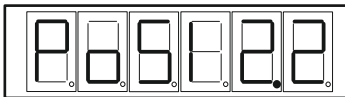



Press  and use the keys   to enter the measured actual value in which the machine is and confirm with  and the message POSIZ2 (POSITION2) will appear on the display:

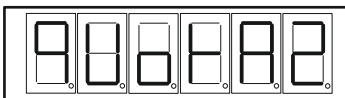

Using the forward-manual and back-manual inputs, position yourself on a second note quota, then confirm with the key  and the display will show the word QUOTA2:



Press  and use the keys   to enter the measured real value in which the machine is ; confirm with  and on the display the word CALC CF (COEFFICIENT CALCULATION) will be shown:

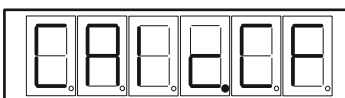

Confirm with the key  and the calculated coefficient value will be shown on the display, for example:

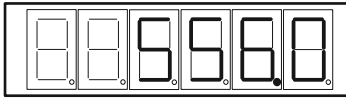

Confirm with the key , you will exit the programming mode and you will return to the initial screen.

4- INERTIA AUTOMATIC CALCULATION MENU (PASSWORD 572)

Inertia is the machine movement from the moment when the instrument disables the outputs to block the movement itself. The instrument has a inertia value self-learning function that allows the automatic setting in a quick and simple way.

It is always possible to manually set the value through the main menu (PASSWORD 569).

To access the INERTIA AUTOMATIC CALCULATION menu from the initial screen:

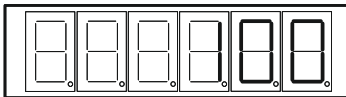

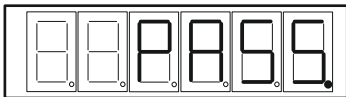

The display shows the current position where the machine is (in this example 100)

Press the button  and the message PASS will appear on the display.



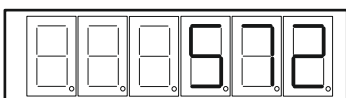

Press  and using the arrow keys   enter the password 572:

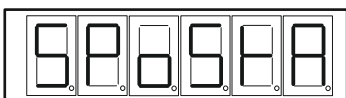

Confirm with the key  to enter the inertia automatic calculation menu and the display shows SPOSTA (MOVE):



Using the forward-manual and manual back inputs, position yourself in a quota that is the lowest reachable, then using the keys   set the quota portion within which you go to sampl inertia, possibly the maximum possible; in this way the inertia calculation will be more precise.

Confirming the entered value with  the machine will start to move automatically by performing

Single-quota positioner

5 slow speed positions, and the set shift value will be shown on the display while the slow forward outputs LEDs 2 and 4 will light up.

Once the positioning has been completed, the instrument performs the inertias arithmetic mean detected during the movements and the message INERZ (INERTIA) appears on the display:

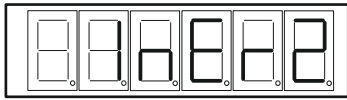

Press the key  and the display will show the read inertia average value, for example:

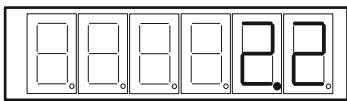

confirm the displayed value with  and then the display shows the message DEV MAX (MAXIMUM DEVIATION):

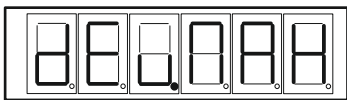

Press the key  and the display will show the maximum deviation measured in the 5 positioning made, for example:

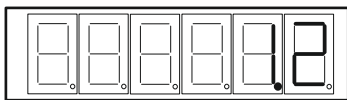

Confirm the displayed value with  and if the calculated inertia value is greater than half of the slowdown quota, the instrument will automatically modify the slowdown quota value and on the display, only in this case, the word Q RALL (SLOWDOWN QUOTA MODIFIED) will be displayed:

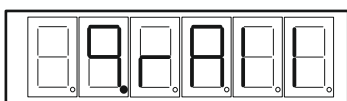

Press the key  and the new slowdown quota value will be displayed, for example:

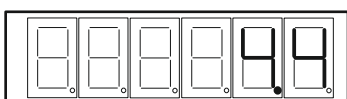

Press the button again  to exit programming.

ELECTRICAL CONNECTION DIAGRAM

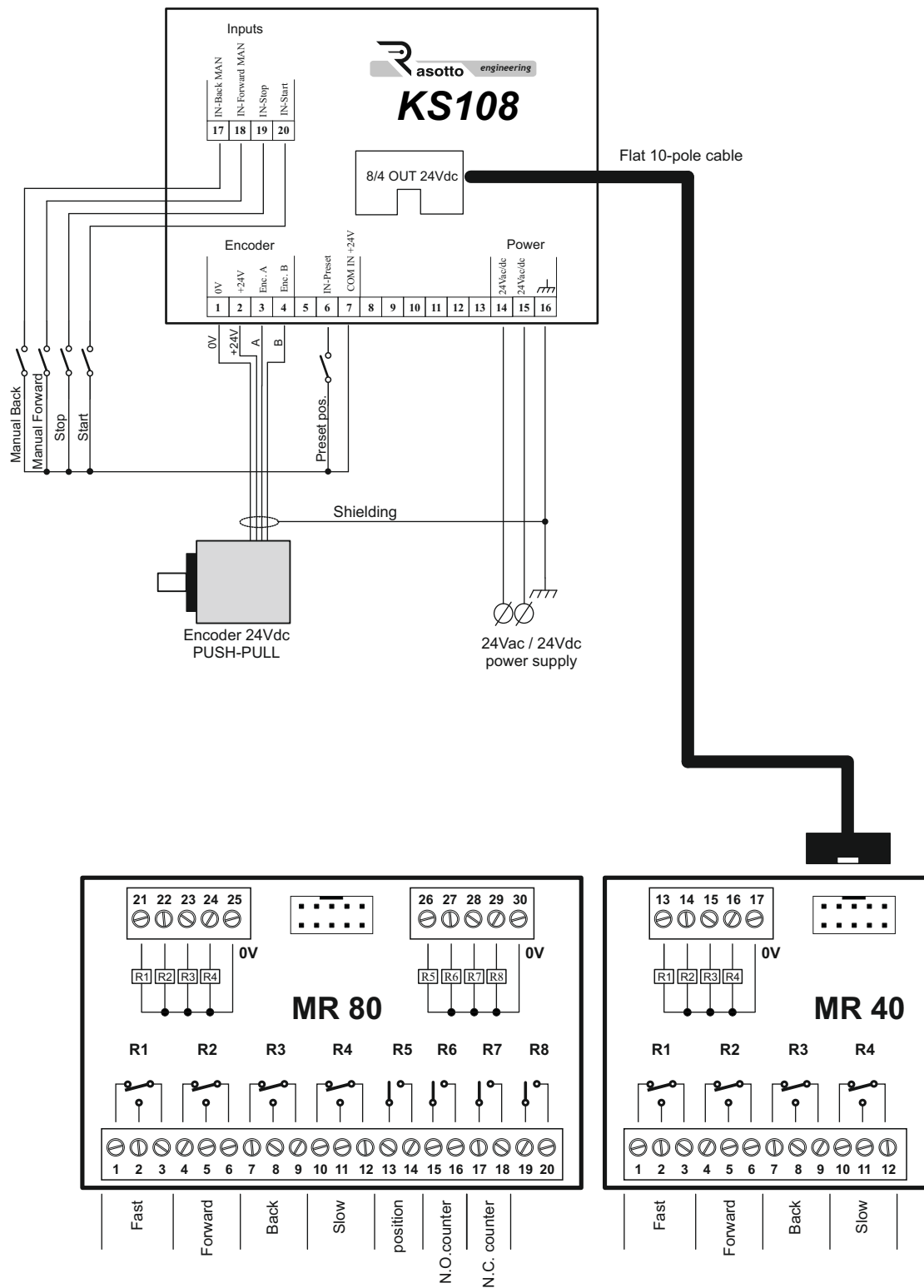

Interface module with 4 relays 24Vdc / 10A



Passive relay interface module that receives commands from electronic equipment such as PLCs, industrial PCs, control modules, etc. and controls inductive and resistive loads of small power such as solenoid valves, contactors, small servomotors, lamps, resistors, etc. This type of module has a series of screw terminals that makes it universal and a multi-pin flat connector for quick connections.

Technical features

| | |
|----------------------|---|
| Power supply | 24Vdc +/- 10% |
| Absorption | Max 150mA |
| Inputs | N.4 digital |
| Contact range | Max 10A / 250V resistive load |
| Wiring | Terminal block + 10-pole cable |
| Signaling | N.4 red LEDs active signal |
| Operation conditions | 0.. +55°C / 20..90% R.U. without condensation |
| Storage conditions | -25.. +80°C / 20..90% R.U. without condensation |
| Mounting | DIN rail EN 50022 |
| Container | DIN bar container |
| Protection degree | IP20 |

Dimensions

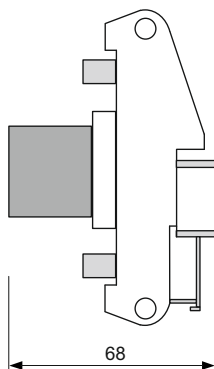

Electrical connections

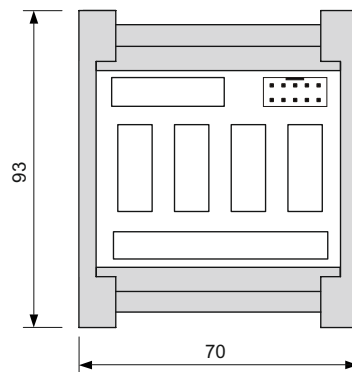
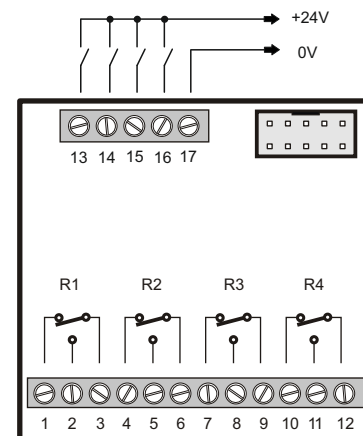

Interface module with 8 relays 24Vdc / 10A

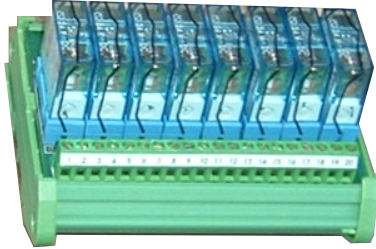

Passive relay interface module that receives digital commands from various electronic devices such as PLCs, industrial PCs, control modules, etc. and controls inductive and resistive loads of small power such as solenoid valves, contactors, small servomotors, lamps, resistors, etc. This type of module has a series of screw terminals that makes it universal and a multi-pin flat connector for quick connection with the whole range of our controllers and instruments.

Technical features

| | |
|----------------------|---|
| Power supply | 24Vdc +/- 10% |
| Absorption | Max 300mA |
| Inputs | N.8 digital |
| Contacts range | Max 10A / 250V resistive load |
| Wiring | Terminal block + 10-pole cable |
| Signaling | N.8 red LEDs |
| Operation conditions | 0.. +55°C / 20..90% R.U. without condensation |
| Storage conditions | -25.. +80°C / 20..90% R.U. without condensation |
| Mounting | DIN rail EN 50022 |
| Container | DIN bar container |
| Protection degree | IP20 |

Dimensions

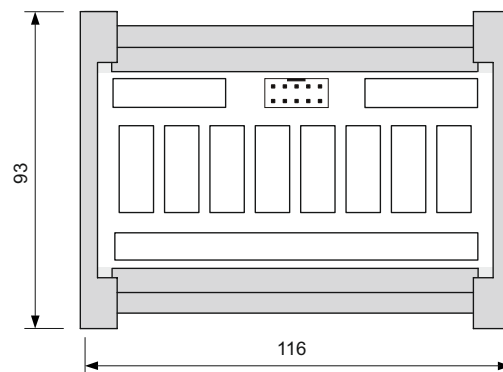
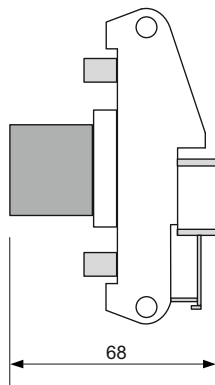

Electrical connections

